



PRECISION ABRASIVE WATERJET SYSTEMS

Equipment Specifications

2626



Shown with Tilt-A-Jet® Accessory.

OMAX® 2626 JetMachining® Center

Smaller work envelope: Compact size, precision abrasivejet machining of smaller parts.

The Model 2626 JetMachining Center cuts complex parts out of most materials including metal, plastic, glass, ceramics and composites – directly from a CAD drawing or .DXF file.

JetMachining is ideal for short-run part production, just-in-time manufacturing, tooling, and prototype part development. No tool changes or complex fixturing reduces setup times by at least 50%.

2626

Standard Features

- Patented “Compute First-Move Later” motion control system including CAD/CAM software with online help.
- Precision X-Y Axis rigidly mounted to the cutting table.
- Pre-loaded linear bearings and precision ball screws.
- Complete component protection against water, dirt, and grit.
- Rapid water level control for submerged cutting.
- Durable abrasive feed system with precision OMAX MAXJET® 5 Nozzle Assembly.
- Ultra-high pressure direct drive pump.
- Hard plumbing.
- Motorized Z-Axis.

Abrasivejet Benefits

- Machines a wide range of materials and thicknesses.
- Does not create heat affected zones or mechanical stresses.
- Rapid setup, no tool changes are required.
- Minimal fixturing required.
- Leaves behind a satin smooth edge, reducing secondary operations.
- No noxious gases, liquids, or oils are used in (or caused by) the machining process.
- Completes most work below 80 dBA for submerged cutting.

The OMAX Technology Guarantee entitles you, as the original owner, to free OMAX software upgrades for the life of the machine.



OMAX 2626 JetMachining Center

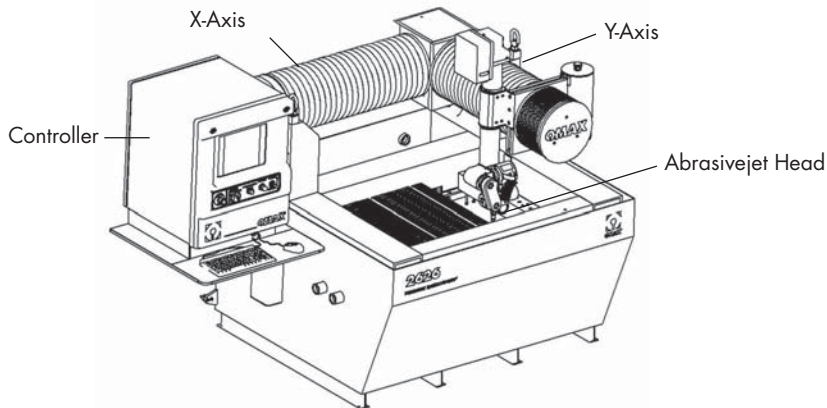

Shown with Tilt-A-Jet Accessory.

Optional Accessories

- Tilt-A-Jet Cutting Head for taper-free parts
- Precision Optical Locator
- Splash Shield Kit
- Solids Removal System (SRS)
- Water-only MAXJET 5 for cutting soft materials
- OMAX MAXJET 5 MiniJet Nozzle Assembly
- Waterjet Brick for cutting thin materials
- 600 lb abrasive delivery system
- Weir Tank
- Z-Axis Drill
- Manual Tilt Z
- Terrain Follower
- Stainless Steel Frame Cover Kit

Machine Dimensions

Footprint	72" x 116"	(1829 mm x 2946 mm)
Weight	3000 lb	(1364 kg)
Height	92"	(2340 mm)
Operating Weight (with water in tank)	6517 lb	(2962 kg)

Work Envelope

X-Y Travel	29" x 26"	(737 mm x 660 mm)
Table Size	46" x 31"	(1168 mm x 787 mm)

(Optional accessories may reduce travel. Contact OMAX for information.)

Computer Control System

Hardware	Personal computer
Control Software	Integrated CAD/CAM system directly uses .DXF files

Drive Description

- Closed loop, digital drives
- Brushless servo motors
- Pre-loaded ball screws, recirculating balls
- Linear bearings with hardened, precision ground ways
- Cantilever Y-Axis on bridge X-Axis

Accuracy of Motion at 70° F

Ball Bar Circularity (Over 12")		
At Max. Traverse Velocity	±0.003"	(±0.08 mm)
Repeatability	±0.0013"	(±0.033 mm)
Squareness	0.0013" per ft	(0.11 mm/m)
Straightness	0.0017" per ft	(0.14 mm/m)
Backlash	0.0007" max.	(0.018 mm)

Speed

- 200 inches per minute standard (5080 mm/min)

Electrical Requirements

- 3-Phase, 380-480 VAC ±10%, 50-60 Hz
- (Note: Contact OMAX for detailed utility requirements. Pumps are built to meet UL and CE specifications.)

Pump Options

- 30 horsepower; 50,000 psi
- 40 horsepower; 55,000 psi

Noise Level

- Below 80 dBA for submerged cutting

Note: Specifications subject to change without notice.

About OMAX

OMAX has the industry leading patented abrasivejet controller with a built-in expert system. The OMAX Software makes it easy to machine precision parts as fast as possible at the lowest cost.

JetMachining is ideal for short-run part production, just-in-time manufacturing, tooling, and prototype part development. It requires no tool changes or complex fixturing, so you can reduce setup times by at least 50%.

For more information on what other OMAX products and accessories can do for you, call us today at 800-838-0343 or visit our website at www.omax.com.



OMAX Corporation

21409 72nd Ave South, Kent, WA 98032
253-872-2300 **tel** 253-872-6190 **fax**
1-800-838-0343 **toll-free**
WWW.OMAX.COM website